

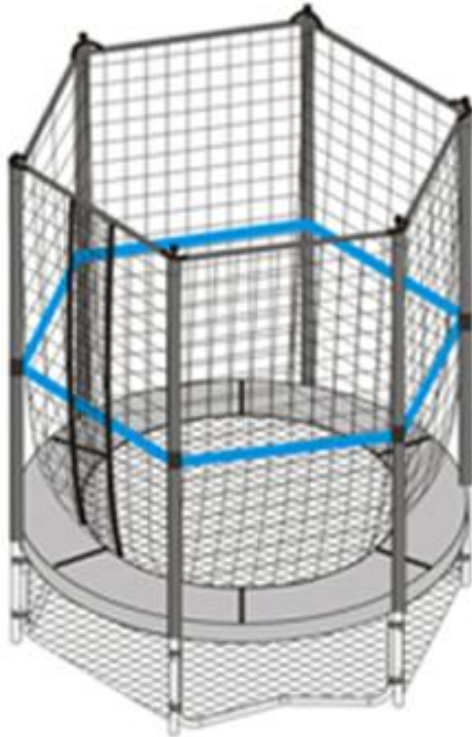

# 55" Trampoline & Enclosure Combo #9005TS

## Owner's Manual

Please read all the instructions before using this product.  
Consult a physician before beginning any, exercise program.



### MANUAL OUTLINE

- Customer Service Information
- Warranty
- Terms of Coverage
- Safety Information
- Hardware Identifier
- Assembly Instructions
- How To Use
- Exercises

This trampoline is subject to a 120lb (54kgs) weight limit.  
Do not allow more than one person on the trampoline at a time.  
Do not allow young children to use unless supervised by an adult.  
**ADULT ASSEMBLY REQUIRED**

### WARNING!

WEIGHT LIMIT:  
120lbs.

### WARNING!

This product is not suitable for children under 3 years of age. It contains small parts which may cause choking.



Pure Fun is a Trademark of  
JamzProducts.net

[www.JamzFitness.com](http://www.JamzFitness.com)

## **OWNERS MANUAL CUSTOMER SERVICE INFORMATION**

Thank you for purchasing our **Pure Fun™ 55-inch Trampoline Set**.

At JamzProducts.net, we want all of our customers to be completely satisfied with their purchase. Please take time to review the contents of the product you just received to make sure that all of the parts are included. If you find that any parts are missing or damaged, we will happily provide replacement parts at no charge within 30 days of purchase. Please keep in mind that for select damaged part replacement requests, we require a photo for submission to our quality control office.

To order these parts, or if you have any other questions or concerns about this JamzProducts.net product, please e-mail the JamzProducts.net customer service department at [customerservice@jamzproducts.net](mailto:customerservice@jamzproducts.net) or contact us at 1-866-498-5269. You can also visit our website at: [www.JamzProducts.net](http://www.JamzProducts.net).

If you request replacement parts, please be sure to include the following information in your correspondence:

**YOUR NAME**  
**YOUR MAILING ADDRESS**  
**YOUR EMAIL ADDRESS**  
**RETAILER WHERE YOU PURCHASED PRODUCT**  
**DATE OF PURCHASE**  
**ORDER # (IF AVAILABLE)**  
**PRODUCT MODEL #: 9005TS**  
**SERIAL #**  
**PRODUCT NAME: 55-inch TRAMPOLINE SET**  
**PART # (located in manual)**  
**QUANTITY NEEDED**  
**PICTURE OF DAMAGED PART(s) – SUBMIT VIA Email , Fax, or Mail**

Again, thank you for purchasing a JamzProducts.net product.

Sincerely,  
Customer Service  
JamzProducts.net  
[www.JamzProducts.net](http://www.JamzProducts.net)  
1-866-498-5269

## LIMITED WARRANTY

### Limited Warranty

JamzProducts.net warrants this product to be free from defects in workmanship and materials under normal use and conditions for a period of as outlines below **FROM THE DATE OF ORIGINAL PURCHASE**. This Limited Warranty is not transferable and is available only for the original purchaser of the Product. The Company's obligation under this warranty is limited to replacing or repairing the Product, at the discretion of the Company.

The various components of the trampoline/enclosure are warranted against defects and workmanship for the time periods specified as follows:

Steel Frame: 2 years

Frame Pad: 6 months

Jumping Surface: 1 year

All Other Parts: 90 days

All warranty coverage extends only to the original retail purchaser from the date of purchase.

Pure Fun's obligation under this Warranty is limited to replacing or repairing, at Pure Fun's option, the product at one of its authorized service centers. All products for which a warranty claim is made must be received by Pure Fun at one of its authorized service centers and accompanied by sufficient proof of purchase (photocopy of the original store receipt, indicating the date of purchase). All freight and handling fees are the responsibility of the consumer to pay, both to and from Pure Fun. All warranty claims must be preauthorized by Pure Fun. Preauthorization can be obtained by calling 866-498-5269. This warranty does not extend to any product or damage to a product caused by or attributable to freight damage, abuse, misuse, improper or abnormal usage, or repairs not provided by a Pure Fun authorized service center or for products used for commercial or rental purposes. This warranty does not cover ordinary wear and tear, weathering, failure to follow directions, improper installation, improper maintenance, or acts of Nature (such as damage caused by wind, lightning, snow, water, or ice). Weather damage, damage caused by unauthorized repair work or damage caused by improper use of the products are not covered by the product warranty. No other Warranty beyond that specifically set forth above is authorized by Pure Fun.

**PURE FUN IS NOT RESPONSIBLE OR LIABLE FOR INDIRECT, SPECIAL OR CONSEQUENTIAL DAMAGES ARISING OUT OF OR IN CONNECTION WITH THE USE OR PERFORMANCE OF THE PRODUCT OR OTHER DAMAGES WITH RESPECT TO ANY ECONOMIC LOSS, LOSS OF PROPERTY, LOSS OF REVENUE OR PROFITS, LOSS OF ENJOYMENT OR USE, COST OF REMOVAL, INSTALLATION OR OTHER CONSEQUENTIAL DAMAGES. SOME STATES DO NOT ALLOW THE EXCLUSION OR LIMITATION OF INCIDENTAL OR CONSEQUENTIAL DAMAGES. ACCORDINGLY, THE ABOVE LIMITATION MAY NOT APPLY TO YOU.**

**THE WARRANTY EXTENDED HEREUNDER IS IN LIEU OF ALL OTHER WARRANTIES AND PURE FUN SPECIFICALLY DISCLAIMS ANY IMPLIED WARRANTY OF MERCHANTABILITY OR FITNESS FOR A PARTICULAR PURPOSE IS LIMITED IN ITS SCOPE AND DURATION TO THE TERMS SET FORTH HEREIN. SOME STATES DO NOT ALLOW LIMITATION ON HOW LONG AN IMPLIED WARRANTY LASTS. ACCORDINGLY, THE ABOVE LIMITATION MAY NO APPLY TO YOU.**

This warranty gives you specific legal rights. You may also have other rights, which vary from state to state.

**READ THIS FIRST!!!**



**WARNING**

**CHOKING HAZARD – Small parts**

**! Warning!**

**While every attempt is made to ensure the highest degree of protection in all equipment, we cannot guarantee freedom of injury. The user assumes all risks of injury due to use. All merchandise is sold on this condition, which no representative of the company can waive or change.**



# WARNING

## IMPORTANT – PLEASE READ! WARNING – GENERAL SAFETY ADVICE

- Please read the instructions before use and retain for future reference.
- Ensure the trampoline and enclosure have been assembled correctly, per the instructions in the manual.
- It is essential that the intended site for this trampoline is completely flat and level. If the ground is not level this will cause movement in the frame and could cause stress on the joined sections.
- This trampoline set is only recommended for use by children **3 YEARS + OF AGE**.
- **DO NOT** exceed the recommended **MAXIMUM WEIGHT** limit of **120lbs (55kgs)**.
- **DO NOT** allow more than one person on the trampoline or in the enclosure at a time.
- **DO NOT** wear glasses or helmets when using the trampoline set.
- **DO NOT** fall or bounce on your knees, this can cause injury.
- **DO NOT** use the trampoline set in wet, windy, or other adverse weather conditions.
- **DO NOT** somersault – this can cause serious injury resulting in paralysis or death.
- **ALWAYS** make sure you have more than ample clearance (8 feet min.) around the trampoline from pools, spas, or other bodies of water, roadways/driveways, drainage ditches, hills, or other sloping/unlevel ground, patio furniture, sports/recreation equipment, outdoor fixtures, outbuildings, walls, or any other obstacles or hazards which may be located on or near the ground.
- **DO NOT** allow other persons to go under, sit, stand or lie on the frame pads while the trampoline is in use.
- **DO NOT** use the trampoline when under the influence of alcohol, drugs or medication which may impair the jumper's judgement and/or coordination.
- **NEVER** attempt to rebound off of, swing or hang from the Safety Net or enclosure Poles, nor intentionally attempt to jump into or over the netting, as this may result in serious injury, paralysis or death and severe damage to the enclosure and trampoline. Pure Fun™ will not be responsible for any damage to the trampoline and/or enclosure nor be liable for consequential injuries resulting from these practices.
- **NEVER** use the enclosure Poles or Safety Net as a handhold or grip to assist in entering or exiting the trampoline. This will result in damage to your enclosure, for which Pure Fun™ is not responsible.
- **ALWAYS** wear socks when using the trampoline.
- **ALWAYS** remove jewelry, belt buckles, or any other sharp objects before using the trampoline.
- **ALWAYS** jump in the middle of the trampoline bed.
- **ALWAYS** follow the safety warnings stated with your trampoline instructions in conjunction with using enclosure.
- **ALWAYS** secure the trampoline set against unauthorized and unsupervised use.
- **NEVER** wear footwear (e.g. shoes) when using the trampoline.
- Children **MUST NEVER** use the trampoline set unless supervised by a responsible adult with knowledge of trampoline use.
- Children **MUST NEVER** be left unattended inside the enclosure at any time.
- **NEVER** let children take items or toys into the enclosure or on the trampoline mat.
- The enclosure is **ONLY** intended to be used to reduce the risk of injury from falling off the trampoline.
- We only recommend using this enclosure with Pure Fun™ Trampolines. Any alterations to the construction or materials of this enclosure or deviations from the assembly instructions may result in unforeseeable safety compromises, and the consumer assumes all responsibility for doing so.
- **ALWAYS** ensure the entrance to the enclosure is fully **closed and secure** before jumping on Trampoline.
- **NEVER** attempt to crawl under or climb over the Safety Net to enter/exit the enclosure area.

- Only the door of the trampoline enclosure should be used to enter or exit the enclosure.
- Before using this product, inspect and replace any worn, defective or missing parts.
- Ensure the trampoline is on level ground with a minimum of 8 feet clear space around the sides, 16 feet clear height space above, and that nothing is under the trampoline.
- Mount and dismount the trampoline with care as injury may result. Children should be assisted when entering and exiting the enclosure to do reduce the risk of falling.
- The frame of your trampoline is made of steel and it will conduct electricity. No electrical equipment (lights, heaters, etc.) should be permitted in or on the enclosure under any circumstance
- If the Safety Net material or any other part of the enclosure becomes damaged, cease using the trampoline immediately. Either remove the net and enclosure frame from the trampoline **entirely** and continue use at your own risk, or cease use until you obtain the necessary replacement parts.
- This Safety Net and enclosure is **ONLY** intended to help prevent accidental falls from the trampoline mat/bed, and then **ONLY** during recommended jumping exercises as described in Pure Fun™ Trampoline manuals.
- Please read and refer to other warnings and use information in the trampoline and enclosure instructions before use.
- Dispose of all packaging materials safely and per local ordinance.

**Please retain this information for future reference.**

**The maximum weight capacity for your product is: 120lbs (55KGS)**

**NOT for children under 3 years.**

## TRAMPOLINE PLACEMENT

The minimum overhead clearance required is 16 feet (5 meters). Ensure that no hazards or obstructions are near the trampoline such as tree branches, swing sets, swimming pools, electrical power wires, walls, fences, etc.

Please be aware of the following when selecting a place for your trampoline:

- ✘ Trampoline must be placed on a level surface
- ✘ The area must be well-lit.
- ✘ All obstructions from overhead, underneath or around the trampoline must be removed.
- ✘ Do not use this trampoline indoors
- ✘ Do not use this trampoline on any slippery floor surface, uneven or sloping ground surface
- ✘ Do not situate trampoline on hard surfaces, concrete etc, as this can damage the frame

The consumer assumes all responsibility for any damage or injury occurring from deviation from these guidelines.

### **WARNING!**

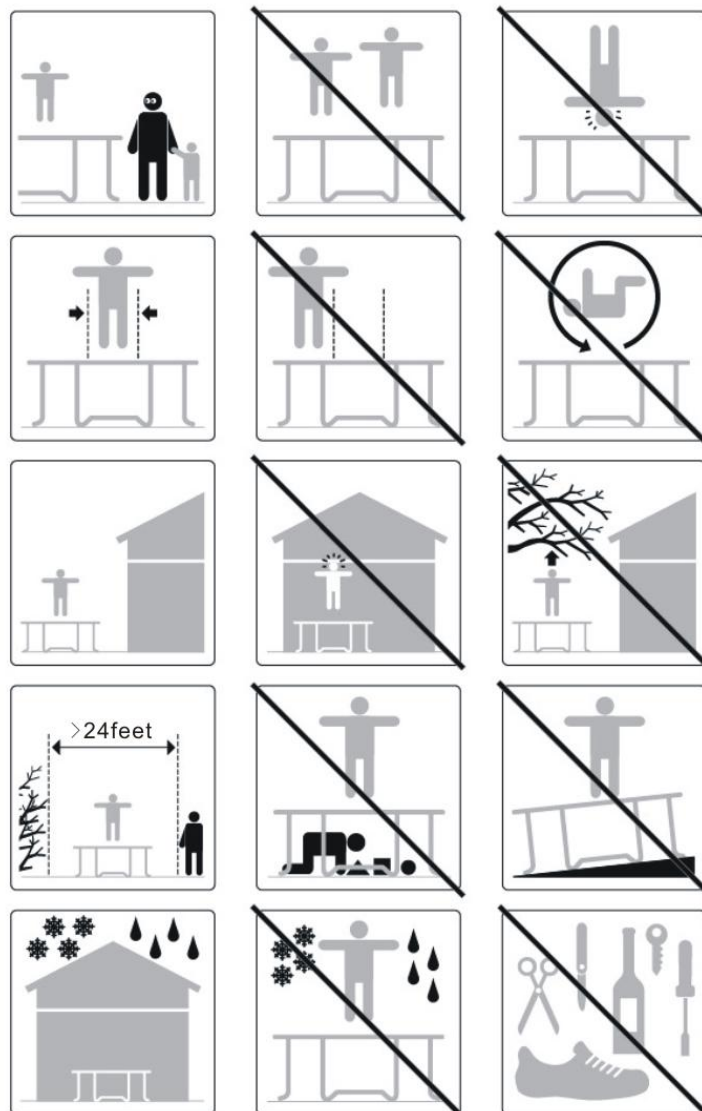

## Care & Use

- This trampoline and enclosure must be assembled by an adult. It must be erected exactly as detailed in the assembly instructions. Enlisting the aid of a helper will make assembly easier. This product should only be used by children over the age of 3. Please ensure children under the age of 3 years old do not play with or are given any part of this trampoline when being assembled or when complete as it contains small parts which may pose a choking hazard.
- Please take care during assembly as the manufacturing process can sometimes result in the occasional sharp edge and small pieces of waste metalwork. The use of gloves to protect your hands from pinch points during assembly is also recommended. Should there be any missing parts; the trampoline must not be used until replacement parts have been fitted.
- Your trampoline must be placed on a flat and level surface which is well-lit. Under no circumstances should it be positioned on a hard surface such as concrete or asphalt, unless the ground under the trampoline plus the recommended free space area is covered with a safety surface. Examples of suitable surfaces are grass, sand or a play surface intended for this trampoline. It is important not to place or store anything under your trampoline. Please also read the instructions accompanied with your trampoline.
- **HIGH WINDS** - It is possible for the trampoline to be blown about by high winds. If you anticipate high winds, the trampoline set should be moved to a sheltered location, or be disassembled. Pure Fun™ is not responsible for any damage to property or product resulting from wind or extreme weather

## Usage

This trampoline is designed and made for family domestic use only within the recommended weight limit 120lbs (55kg). This trampoline is not intended for use outside of these guidelines. The user must remove footwear (shoes) before use. The user must wear socks when using the trampoline. Misuse can result in injury. Inspect the trampoline before use and always replace worn, defective or missing parts. The frame pad should always be fitted properly, fully covering the trampoline frame and springs, and the enclosure net should always be securely fastened.

## Supervision

- Children must always be supervised while they are playing on the trampoline and must be instructed not to use the trampoline in an inappropriate or hazardous manner.

## Remember!

- Trampolines are rebounding devices which propel the user to unaccustomed heights, and into a variety of body movements. Rebounding off of the trampoline, striking the frame or Elastic buckles, or improperly landing on the trampoline mat (bed) may cause injury.

**Safety Information:** This trampoline is designed and manufactured to provide you and your family with many years of fun and exercise but, for your benefit and safety, please read this manual carefully and in full before assembling and using your trampoline.

- Never allow more than one (1) person on the trampoline at a time. Multiple jumpers increase the chance of someone becoming injured. Jumpers may collide with one another, fall off the trampoline, fall on or through the springs, or land incorrectly on the mat. Multiple jumpers increase the chances of loss of control, collision, and falling off. This can result in broken head, neck, back or leg.

- Always secure the trampoline against unauthorized and unsupervised use.
- The frame of your trampoline is made of steel and it will conduct electricity. No electrical equipment (lights, heaters, extension cords, household appliances, etc.) should be permitted in or on the enclosure under any circumstances to avoid the risk of electrocution.
- As your trampoline mat is raised off the ground, there is the risk of a fall when exiting the trampoline through the door of the enclosure. Children should be assisted when entering and exiting the enclosure so to reduce their risk of falling.
- Only the door of the trampoline enclosure should be used to enter or exit the enclosure.
- Do not land on head or neck. Paralysis or death can result even if you land in the middle of the trampoline mat (bed). To reduce the chance of landing on your head or neck, do not do somersaults (flips).
- We recommend that the user does not wear loose-fitting clothing or jewelry that may catch or snag during play. Children should NOT wear helmets while playing on the trampoline. Ensure that younger children do not walk or crawl underneath the trampoline and keep the area around and underneath free from all solid objects at all times.

**IMPORTANT** - You must not use the trampoline if you have a medical history of neck or back injuries or a mental or physical condition – an existing condition or injury dramatically increases the risk of serious injury or death

No modification should be carried out to the trampoline or any of its components. Any modification could lead to damage to the product or to personal injury.

**Weather Conditions:** Special care should be taken as weather conditions change. In particular, a wet trampoline mat (bed) is too slippery for safe jumping. Gusty or severe winds can cause jumpers to lose control. To reduce the chance of injury, use the trampoline only under appropriate weather conditions. In cold weather, tongues and lips can stick to metal work at sub zero temperatures. In warmer and sunnier weather, parts can become hot, and the temperature should be regularly checked during play, especially metal parts

**HIGH WINDS:** It is possible for the Trampoline to be blown about by high wind. If you anticipate high winds, the Trampoline should be moved to a sheltered location, or be disassembled. Pure Fun™ is not responsible for any damage to property or product resulting from wind or extreme weather.

### **Jumper's Role In Preventing Accidents**

Education is key to safety. Read, understand, and practice all safety precautions and warnings prior to using the trampoline. A controlled jump is when you land and take off from the same point on the mat. For additional safety tips and instructions, contact a certified trampoline instructor

- Stay in control of your jumps. **DO NOT** move onto more complicated or more difficult maneuvers until you have mastered the basic, fundamental bounce.
- Always bounce at the center of the bed. Bouncing near the edge of the bed can lead to injury and can also stretch the springs. The frame pad is not designed nor intended to support the weight of the trampoline user. Do not step or jump directly onto the frame pad.
- Avoid bouncing too high. Stay low until you can control your bounce and land consistently in the middle of the bed.
- To regain control and stop your jump, bend your knees quickly when you land.
- Do not use the trampoline when under the influence of alcohol, drugs or other medications.
- Allow each jumper a brief turn on the trampoline. Extended bouncing exposes an over tired user to an increased risk of injury. Longer turns tend to lessen the interest of others waiting to jump.

- The trampoline mat is several feet from the ground. Jumping off the trampoline to the ground or any other surface may result in injury. Jumping onto the trampoline from a roof, deck, or other object also represents a risk of injury. Smaller children may need assistance getting up on or down from the trampoline. Mounting and dismounting properly should be a strict rule from the very beginning. Users should climb onto the trampoline by placing their hands on the frame and stepping or rolling up onto the frame, across the springs, and onto the mat (bed). Do not step directly on the frame pad or grasp the frame pad when mounting or dismounting the trampoline. Users should always place their hands on the frame while mounting or dismounting. To dismount, jumpers should walk to the side of the mat (bed), bend over and place one hand on the frame, then step from the mat to the ground.
- Injury may result from hitting the frame or falling through the springs while jumping or getting on or off the trampoline. Stay in the centre of the trampoline mat when jumping. **BE SURE TO KEEP THE FRAME PAD IN PLACE TO COVER THE FRAME AT ALL TIMES.** The frame pad is not designed nor intended to support the weight of the trampoline user. Do not step or jump directly onto the frame pad
- The enclosure and safety net is designed and made for family domestic use only by people 3 years and older. It is not a rebounding device. It is designed as an enclosure to control entry and exit to and from the trampoline and, allow jumpers to gain confidence, balance, coordination and agility without the fear of rebounding off the trampoline, where injury could occur.

### **Supervisor's Role in Preventing Accidents**

- It is the responsibility of the supervisor(s) of trampoline users to provide knowledgeable and mature supervision. Do not supervise a child's use of the trampoline when under the influence of alcohol, medications or other drugs. A supervisor needs to know and enforce all the rules and warnings set forth in this manual in order to minimize the likelihood of accidents and injuries and to inform users of these rules. During periods of time when supervision is unavailable or inadequate, this may require that the trampoline be disassembled, placed in a secure area, or otherwise secured against unauthorized use. It is the responsibility of the supervisor(s) to be sure that the users are fully aware of the safety guidelines which are printed on the pads.
- Children should always be supervised while they are playing on the trampoline fitted with an enclosure and should be instructed not to use it in an inappropriate or hazardous manner. In particular be aware of:
  - The objects children bring into the enclosure
  - Children's activities inside the enclosure
  - Conditions inside the enclosure when children are using it
  - The way children get into and out of the enclosure

### **Disposal Information**

- Never allow the trampoline parts to be placed or used near a fire. When it becomes necessary to dispose of your equipment, remove all bolts and disassemble. Store safely & out of reach for children until it can be properly disposed of. Remember to dispose of it in a safe place and manner so as not to present any hazards to any individuals.
- Check with your local authority or retailer for recycling or disposal advice.  
These instructions are issued in the interest of general safety for the public.



**Misuse and abuse of this trampoline is dangerous and can cause serious injury or death**

## IMPORTANT

It is essential that the intended site for this trampoline is completely flat and level. If the ground is not level this will cause movement in the frame and could cause stress on the joined sections. The recommended safe play area is 8 feet

**REMOVE all obstacles from play area.**



The safe play area must be on level ground, free from all structures, landscaping, trees and branches, rocks, wires, sprinkler heads and other obstacles. Children can be seriously injured running or colliding into such obstacles.

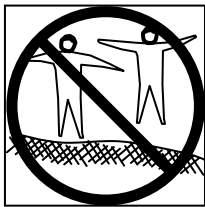

**NO MORE THAN ONE PERSON AT A TIME  
ON THE TRAMPOLINE!! MULTIPLE JUMPERS  
INCREASE THE RISK OF INJURY SUCH AS  
BROKEN NECK, LEG, BACK OR HEAD INJURY  
RISK OF SERIOUS INJURY OR DEATH**



**DO NOT PERFORM SOMERSAULTS (FLIPS)  
AS THIS WILL INCREASE RISK OF LANDING  
ON HEAD OR NECK RESULTING IN INCREASED**

# PACKAGE CONTENTS

PART NO	NAME	Q'TY
1	Trampoline Mat	1
2	Frame Pad	1
3	Leg Base	3
4	Top Rail with Leg Sockets	6
5	Spherical Elastic buckle	30
6	Elastic buckle	6
7	Steel Pipe A	6
8	Steel Pipe B	6
9	Steel Pipe C	6

PART NO	NAME	Q'TY
10	Pole Cover	6
11	Safety Net	1
12	Safety Skirt	1
13	M6X60 Hex Bolt	12
14	M6 Nylon Washer	24
15	M6 Screw Set	12
16	Safety Nut	12
17	Wrench	2
18	Steel Wire	1

1.

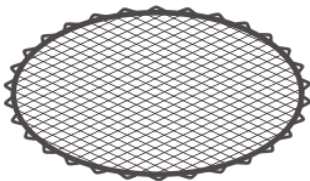

2.

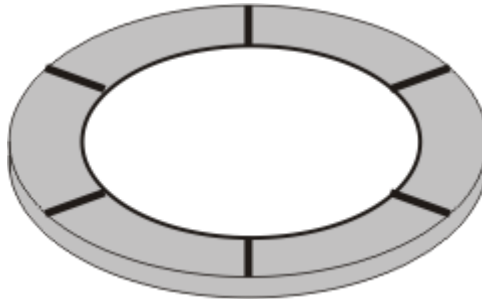

3.

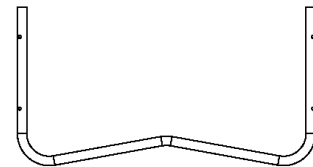

4.



5.



6.



7.



11.

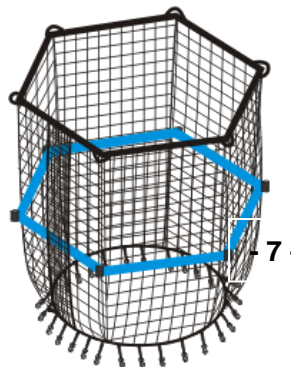

12.

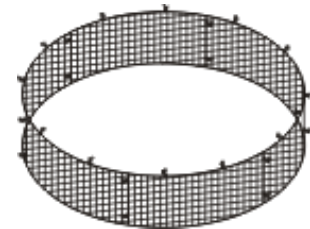

8.



9.



10.



13.



14.



15.



16.



17.



18.



We make every effort to present the most current specifications and product features when printing this literature. As a result of our policy for continual improvement, however, changes may be made in equipment, availability, specifications and features without notice.

## ASSEMBLY INSTRUCTIONS

- Prior to assembling the trampoline, use the above parts list to make sure all parts are present. If any parts are missing, please contact your place of purchase for assistance.
- Please dispose of all packing material carefully and keep it away from children.
- Take a few moments to familiarize yourself with the contents & instructions before attempting assembly.
- When you are ready to start, make sure you have the right tools at hand, adequate space and area for assembly.
- Adult ASSEMBLY REQUIRED. Two adults are needed to assemble this trampoline.
- Please wear gloves to protect your hands and prevent any injuries from pinch points.
- 

**Step 1:** Assemble Trampoline frame by snapping the pieces together as detailed below.

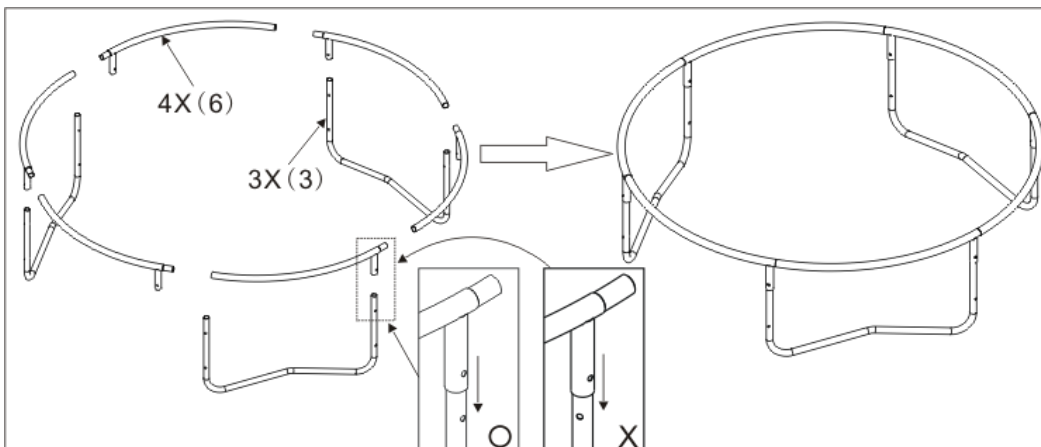

**Step 2:** Attach Steel Pipe A (7), to the trampoline frame using the included wrench as detailed below.

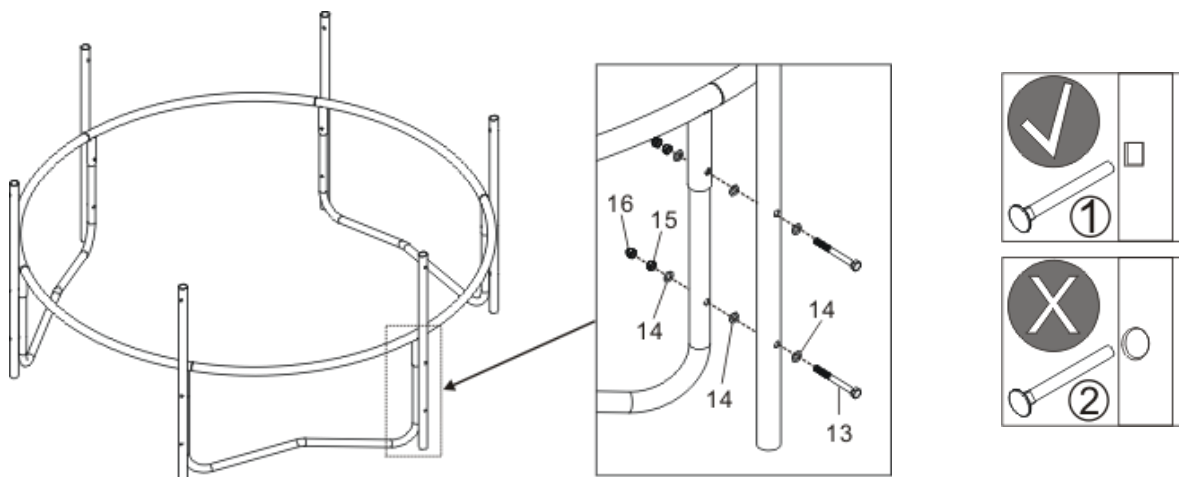

**Step 3: Trampoline Mat Assembly**

Insert a Spherical Elastic buckle (5) through each fabric loop on the trampoline mat. If needed, use the Steel Wire (18) as shown in Figure A to pull the buckle through the fabric loops on the trampoline mat. Make sure to rotate the ball end of each buckle down to the underside of the mat (see Figure E). Repeat for the other Spherical Elastic buckles. Please be careful of pinch points during assembly

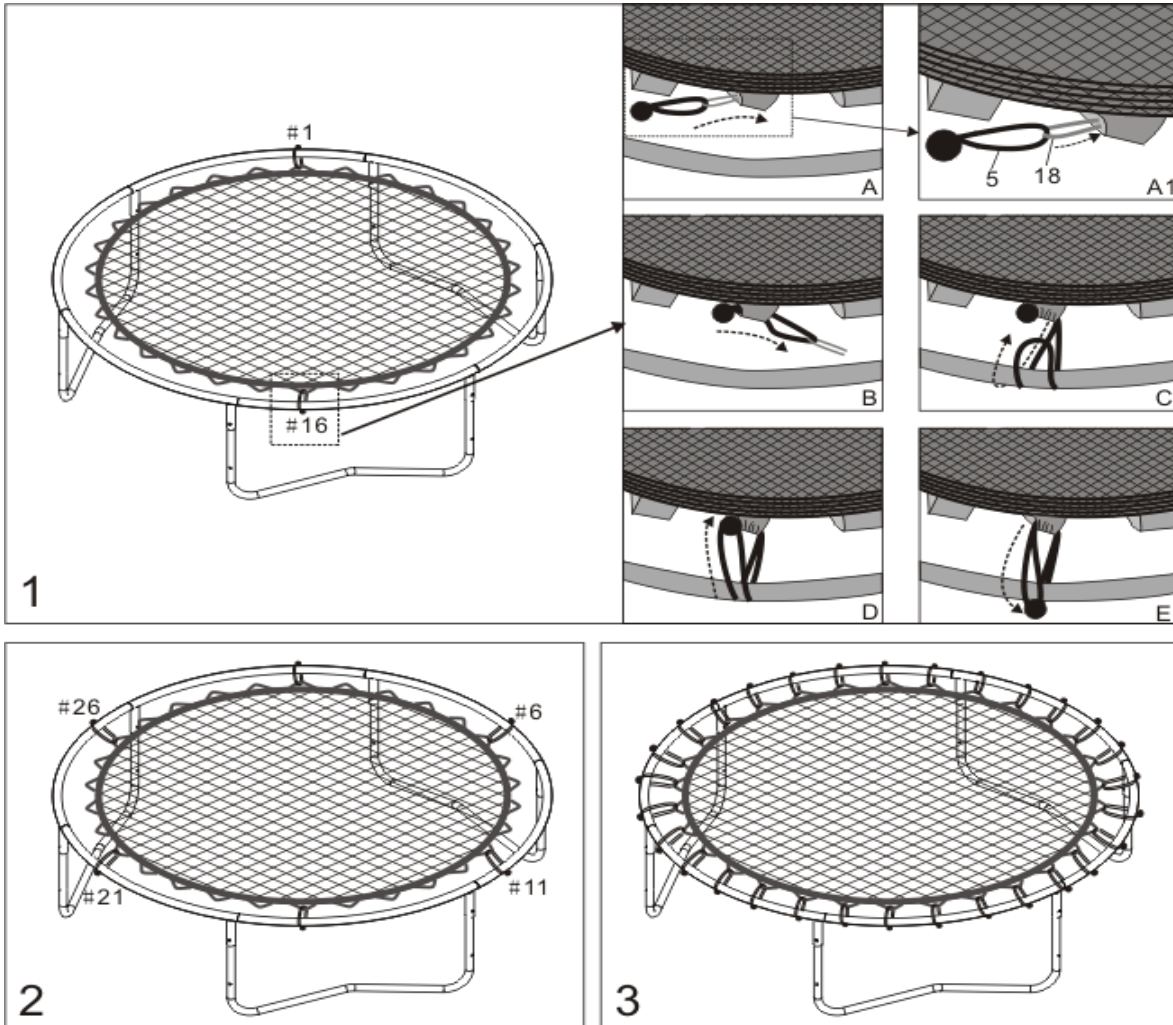

**Step 4: Attach Safety Skirt (12) with straps as shown below.**

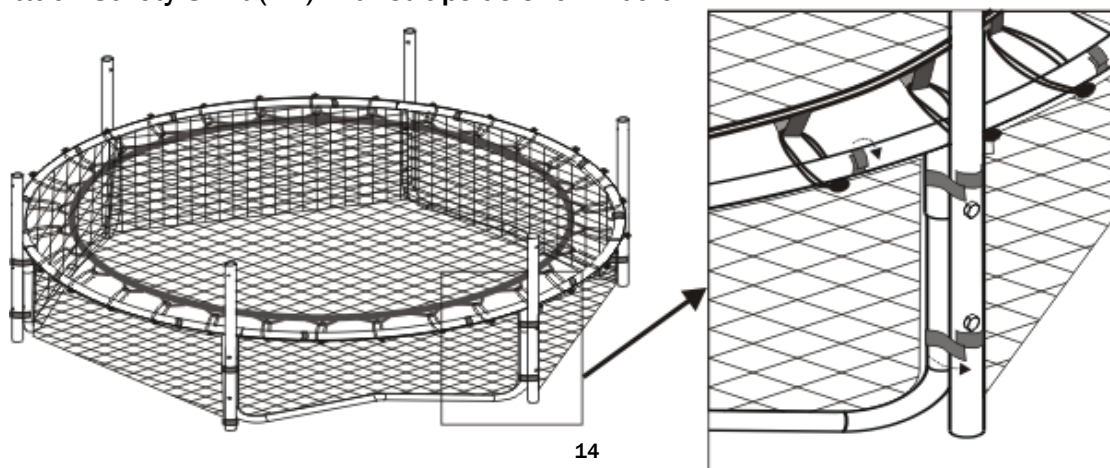

**Step 5:** Connect Steel Pipes B (8) and C (9) together as shown in Figure 1.



**FIGURE 1**

**Step 6:** Connect Steel Pipes B (8) and C (9) to Steel Pipes A (7). Once attached, place the Pole Covers (10) onto the assembled enclosure poles.

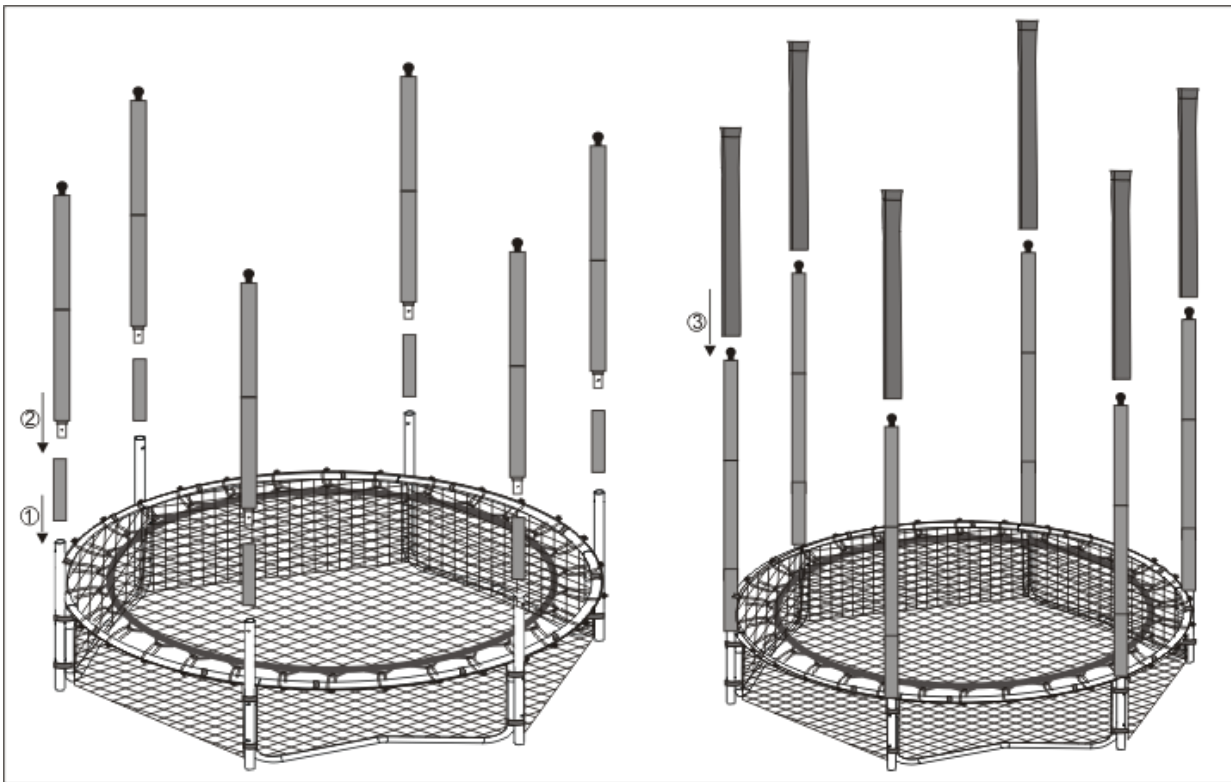

**Step 7: Safety Net and Frame Pad Assembly**

(1) Lay the Frame Pad (2) over the trampoline so that the Spherical Elastic buckle and the steel frame are covered. Please ensure that the Frame Pad covers all metal parts.

(2) See the diagrams below to attach the Safety Net.

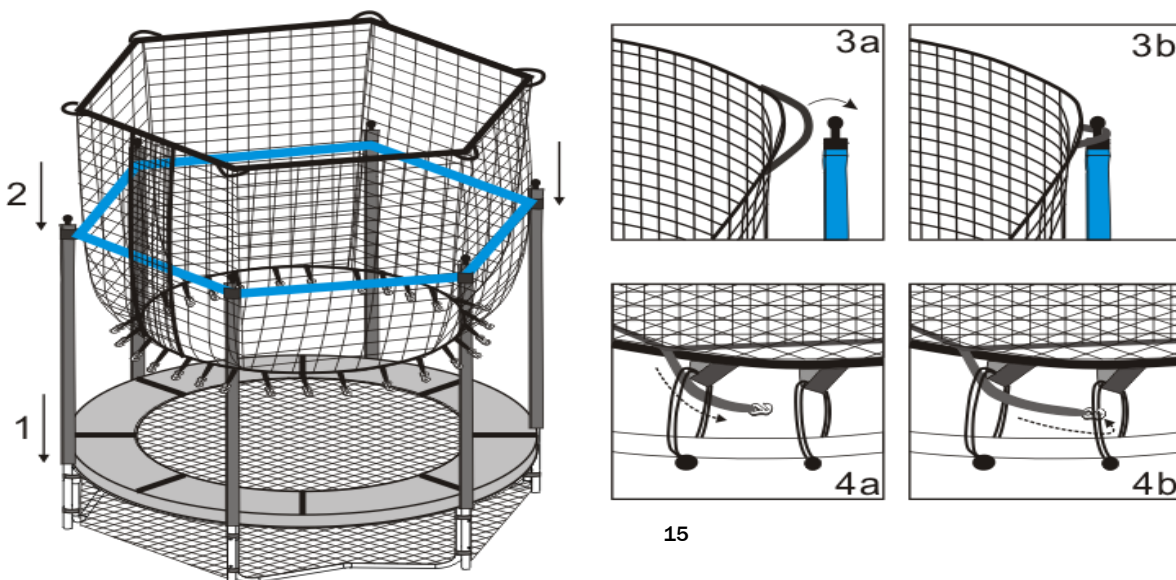

**Step 8: Frame Pad Assembly**

Tie the Elastic buckle (6) located at the under side of the frame pad to the frame.

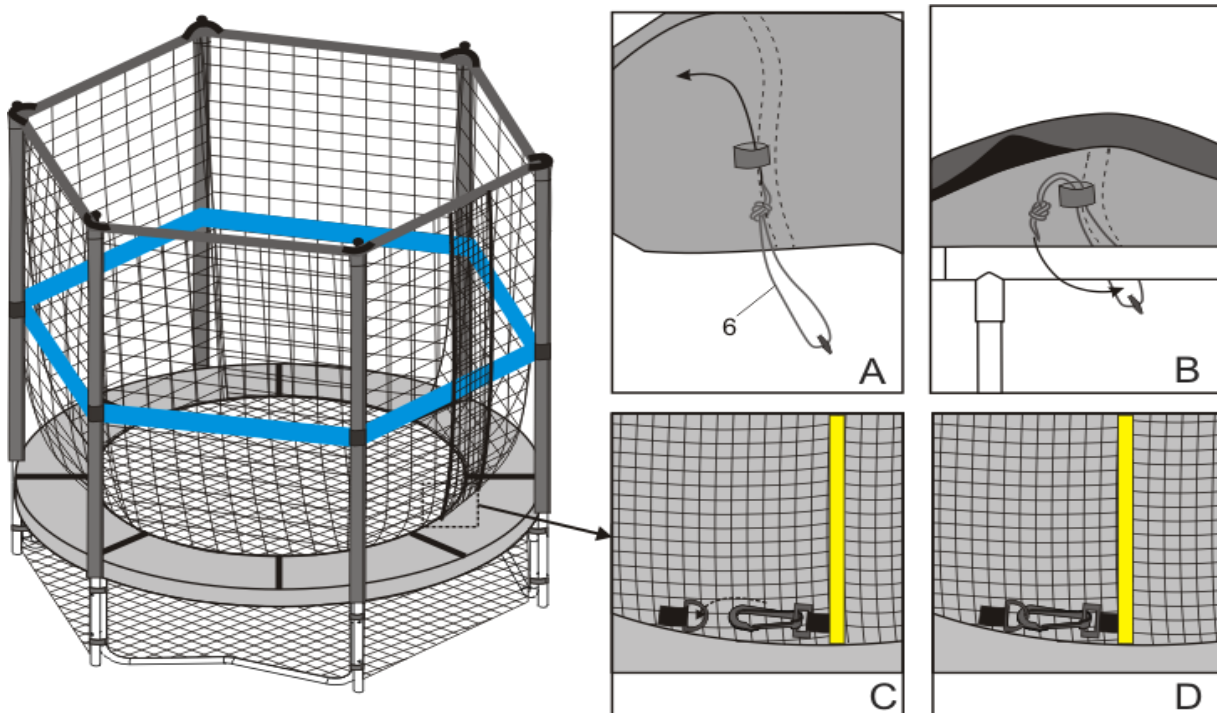

**DO NOT ENTER OR EXIT THE TRAMPOLINE WITH THE DOOR CLIP LOCKED. DOING SO WILL CAUSE THE ENCLOSURE POLES TO BEND, OR OTHERWISE DAMAGE THE ENCLOSURE.**

**PLEASE LOCK THE ENTRANCE WHEN TRAMPOLINE IS IN USE, BEFORE YOU START USING THE EQUIPMENT**

## How To Use Your Trampoline

- Always bounce at the center of the bed. Bouncing near the edge of the bed can lead to injury and can also stretch the Springs. The frame pad is not designed nor intended to support the weight of the trampoline user. Do not step or jump directly onto the frame pad.
- Avoid bouncing too high. Stay low until you can control your bounce and land consistently in the middle of the bed.
- To regain control and stop your jump, bend your knees quickly when you land.
- **NEVER** use the Enclosure Poles or Safety Net as a handhold or grip to assist in entering or exiting the trampoline. This will result in damage to your Enclosure, for which Pure Fun™ is not responsible.
- **NEVER** attempt to rebound off of, swing or hang from the Safety Net or Enclosure poles, nor intentionally attempt to jump into or over the netting, as this may result in serious injury, paralysis or death and severe damage to the Enclosure and Trampoline. Pure Fun™ is not responsible for any damage to the Trampoline and Enclosure or consequential injuries resulting from the above practices.
- Do not use the trampoline when under the influence of alcohol or drugs.
- Allow each jumper a brief turn on the trampoline. Extended bouncing exposes an over tired user to an increased risk of injury.
- The trampoline mat is well off the ground. Jumping off the trampoline to the ground or any other surface may result in injury. Jumping onto the trampoline from a roof, deck, or other object also represents a risk of injury. Smaller children may need assistance getting up on or down from the trampoline. Mounting and dismounting properly should be a strict rule from the very beginning. Users should climb onto the trampoline by placing their hands on the frame and stepping or rolling up onto the frame, across the Springs, and onto the mat (bed). Do not step directly on the frame pad or grasp the frame pad when mounting or dismounting the trampoline. Users should always place their hands on the frame while mounting or dismounting. To dismount, jumpers should walk to the side of the mat (bed), bend over and place one hand on the frame, then step from the mat to the ground.
- Injury may result from hitting the frame or falling through the Springs while jumping or getting on or off the trampoline. Stay in the centre of the trampoline mat when jumping. **BE SURE TO KEEP THE FRAME PAD IN PLACE TO COVER THE FRAME AT ALL TIMES.** The frame pad is not designed nor intended to support the weight of the trampoline user. Do not step or jump directly onto the frame pad.

## CARE AND MAINTENANCE

- **GENERAL** Your trampoline and enclosure are designed to stand outside all year round and generally requires very little maintenance. However, a little care and forethought can add years to your trampoline's life. Remember that the bed (mat), frame pads and enclosure are made of synthetic materials and are easily damaged by cigarette ends, fireworks and bonfire debris.
- **FRAME** Do not sit or stand on the frame or the frame pads while the trampoline is in use as this restricts the frame's natural reflex action. If surface rust appears it should be removed with either a wire brush or coarse sandpaper, and the area treated with a non-toxic paint.
- **FRAME PADS** Frame pads are there to protect the user from any fall or landing on the Springs and frame. On **NO** account should people be permitted to sit or stand on them when the trampoline is in use. You should also make sure that smaller users do not use the inside edges of the pads as a "handle" when getting up on the trampoline.

## **CARE AND MAINTENANCE (continued)**

- **THE MAT** The mat (bed) will, over the years, be gradually weakened by the effects of ultra violet radiation. Therefore, the more it can be protected from direct sunlight the longer it will last. A little mold or mildew should not harm the mat. Do make sure that shoes are removed before bouncing and ensure that any other sharp objects such as belt buckles, brooches, and jewelry are removed too.
- **THE SPRINGS** Do **NOT** stand on the Springs while the trampoline is in use. Try not to bounce on to the Springs. They are not designed for this sort of stress and can become stretched and weakened. If you find you have any damage Springs, it is important to replace them as soon as possible to avoid damage to the trampoline mat and avoid overloading and therefore damaging the remaining good springs.
- **THE ENCLOSURE** To avoid damage to the enclosure, do not allow pets or other animals inside. Their claws and teeth can damage the netting and the trampoline mat. Any large trampoline, with or without an enclosure, can be blown around in high winds and cause injury or damage. We recommend that the enclosure should be removed under these conditions and stored in a dry place.
- **NEVER** attempt to rebound off of, swing or hang from the Safety Net or Enclosure poles, nor intentionally attempt to jump into or over the netting, as this may result in serious injury, paralysis or death and severe damage to the Enclosure and Trampoline. Pure Fun™ is not responsible for any damage to the Trampoline and Enclosure or consequential injuries resulting from the above practices.
- **NEVER** use the Enclosure Poles or Safety Net as a handhold or grip to assist in entering or exiting the trampoline. This will result in damage to your Enclosure, for which Pure Fun™ is not responsible.

### **IMPORTANT:**

This trampoline was designed and manufactured with quality materials and craftsmanship. With proper care and maintenance, it will provide all jumpers with years of exercise, fun, and enjoyment. Please follow the guidelines below:

This trampoline is designed to withstand a specific weight and usage. Ensure only one person uses the trampoline at any one time. People over 175 pounds (80kgs) should not use the trampoline. Jumpers should wear socks when using the trampoline. Street shoes or tennis shoes should **NOT** be worn while using the trampoline. To limit damage do not allow pets onto the mat. Jumpers should remove all sharp objects from their person prior to using the trampoline. All sharp or pointed objects should be kept off the trampoline mat at all times.

Always inspect the trampoline before each use for worn, damaged or missing parts. Please be aware of:

- Punctures, holes, or tears in the trampoline mat
- Sagging trampoline mat
- Loose stitching or any kind of deterioration of the mat
- Bent or broken frame parts, such as the legs, top rail sections or enclosure poles
- Broken, missing, or damaged springs
- Torn or ripped fabric in the Safety Net
- Frame Pad not covering springs or top rail.
- Ripped or torn Frame Pad
- Loose hardware (nuts, bolts, spacers, push pins)
- Damaged, missing, or insecurely attached frame pad
- Protrusions of any types (especially sharp types) on the frame, springs, or mat
- No modification should be carried out to the trampoline or any of its components. Any modification could lead to damage to the product or to personal injury.

**IF YOU FIND ANY OF THE PREVIOUS CONDITIONS, OR ANYTHING ELSE THAT YOU FEEL COULD CAUSE HARM TO ANY USER, THE TRAMPOLINE SHOULD BE DISASSEMBLED OR SECURED FROM USE UNTIL THE CONDITION(S) HAS BEEN RECTIFIED.**

## PLEASE RETAIN THIS INFORMATION FOR FUTURE REFERENCE

### INFORMATION ON USE OF THE TRAMPOLINE

Initially, get accustomed to the feel and bounce of the trampoline. The focus must be on the fundamentals of your body position and you should practice each bounce (the basic bounces) until you can perform each with ease and control.

**To break a bounce, flex your knees sharply before your feet come in contact with the mat.**

This technique should be practiced as you are learning each of the basic bounces.

The skill of braking should be used whenever you lose balance or control of your jump.

Always learn the simplest bounce first and be consistent with the control of your bounce before moving on to more difficult and advanced bounces. **A controlled bounce is when your take off point and landing point is the same spot on the mat.** If you move up to the next bounce without first mastering the previous, you increase your risk of injury.

Do not bounce on the trampoline for extended periods of time as fatigue can increase your risk of injury. Bounce only for a brief period of time. Only one person should bounce on the trampoline at a time.

Jumpers should wear a t-shirt, shorts or sweats, and regulation gymnastics shoes, heavy socks, or be barefoot. If you are just beginning, you may want to wear long sleeve shirts and pants to protect against scrapes and abrasions until you master correct landing positions and form. Do not wear hard sole shoes, such as tennis shoes, on the trampoline as this will cause excessive wear on the mat.

You should always mount and dismount properly in order to avoid injury. To mount properly, you should place your hand on the frame and step or roll up onto the frame, over the springs, and onto the trampoline mat. Always remember to place your hands onto the frame while mounting or dismounting. Do not step directly onto the frame pad or grasp the frame pad. To dismount properly, move to the side of the trampoline and place your hand onto the frame as a support and step from the mat to the ground. Smaller children should be assisted when mounting and dismounting.

Do not bounce recklessly on the trampoline, as this will increase your risk of injury. The key to safety and having fun on the trampoline is control and mastering the various bounces. Never try to out-bounce another bouncer in terms of height!

**Children must never use the trampoline without ADULT supervision.**

## **ACCIDENT CLASSIFICATION**

***Mounting and Dismounting:*** Be very careful when getting on and off the trampoline. **DO NOT** mount the trampoline by grabbing the frame pad, by stepping onto the springs, or by jumping onto the mat from any surface (e.g. a deck, roof, or ladder) as this will increase your risk of injury. **DO NOT** dismount by jumping off the trampoline. If small children are playing on the trampoline, they may need help in mounting and dismounting.

***Use of Alcohol or Drugs:*** **DO NOT** consume any alcohol or drugs before or while using this trampoline as this will impair your judgment, reaction time, and overall physical coordination.

***Multiple Jumpers:*** If you have multiple jumpers (more than one person on the trampoline at any one time), you increase the chance of getting injured. Injuries could occur when you fly off the trampoline, lose control, collide with the other jumper(s), or land on the springs. Generally, the lightest person on the trampoline will get injured.

***Striking the Frame or Springs:*** When playing on the trampoline, **STAY** in the center of the mat. This will reduce your risk of injury from the frame or springs. Always keep the frame pad on the frame **DO NOT** jump or step onto the frame pad, it is not intended to support the weight of a person.

***Loss of Control:*** **DO NOT** try difficult maneuvers until you have mastered the previous maneuver as this will increase your risk of injury. A controlled jump is when your take off Point and landing point is the same spot on the mat. If you lose control when you are jumping on the Trampoline, bend your knees sharply when you land and this will allow you to stop your jump and regain control.

***Somersaults (Flips):*** **DO NOT PERFORM** somersaults of any type (backwards or forwards) on this Trampoline as this will increase your risk of injury to your neck or back **WHICH MAY RESULT IN SERIOUS INJURIES LEADING TO DEATH OR PARALYSIS.**

***Foreign Objects:*** **DO NOT** use the trampoline if there are pets, other people, animals or any objects beneath, above or near the trampoline as this will increase the risk of an injury occurring. **DO NOT** hold any foreign objects in your hand and **DO NOT** place any objects on the trampoline. Please be aware of what is overhead when you are using the trampoline. Tree branches, wires, or other objects located above the trampoline may result in injury.

***Poor Maintenance of Trampoline:*** A trampoline in poor condition will increase your risk of injury. Please inspect the trampoline before each use for bent steel tubes, torn mat, loose or broken springs and overall stability of the trampoline.

***Weather Conditions:*** Please be aware of the weather conditions when using the trampoline. Do not use trampoline if the mat is wet. Do not use the trampoline in windy conditions.

***Limiting Access:*** When the trampoline is not in use, always store the access ladder in a secure place to prevent unauthorized and unsupervised access.

## LESSON PLAN

The following lessons are recommended in order to learn basic steps and bounces before moving onto more difficult or complicated bounces. You should read and understand all safety instructions before mounting the trampoline. A complete discussion and demonstration of body mechanics and trampoline guidelines should occur between the supervisor and student.

### Lesson 1

- A. Mounting and Dismounting - Demonstration of proper techniques
- B. The Basic Bounce-Demonstration and practice
- C. Braking (Check the Bounce) - Demonstration and practice. Learn to break on command
- D. Hands and knees - Demonstration and practice. Stress should be on four- point landing and alignment

### Lesson 2

- A. Review and practice of techniques learned in Lesson 1
- B. Knee Bounce-Demonstration and practice. Learn the basic down to knee and back up before trying half twist to left and right
- C. Seat Bounce -Demonstration and practice. Learn basic seat bounce then add a knee bounce, hands and knees; repeat

### Lesson 3

- A. Review and practice skills and techniques learned in previous lessons
- B. Front Drop-All students should be requested to assume the prone position (face down on the ground) while the instructor checks for faulty positions that could cause injury
- C. Start with a hands and knees bounce and then extend body into prone position, land on the mat and return to feet
- D. Practice Routine-Hands and knees Bounce, Front Bounce, back to feet, seat bounce, back to feet

### Lesson 4

- A. Review and practice skills and techniques learned in previous lessons
- B. Half-Turn
  - Start from front drop position. As you make contact with the mat, push off with arms in either the right or left direction and turn head and shoulders in same direction.
  - During turn, be sure to keep back parallel to mat and head up
  - After completing turn, land in front drop position
    - After completing this lesson, the student now has a basic understanding of trampoline bounces.
    - Jumpers should be encouraged to develop their own routines with emphasis on control and form.

A game that can be played in order to encourage students to try and develop routines is "BOUNCE". In this game, players count off from 1 to 10. Player one starts with a maneuver. Player two has to do Player One's maneuver and add on another. Player Three does the maneuvers of One and Two and then adds a third maneuver. This continues until a player cannot do the routine properly in the correct sequence. The first person to miss, receives the letter "B". This continues until someone spells out the word "BOUNCE". The last remaining contestant is deemed the winner! Even when playing this game, it is important to **perform your routines under control**. Do not try difficult or highly skilled bounces that you have not yet mastered.

**A certified trampoline instructor should be contacted to further develop your trampoline skills.**

## **BASIC TRAMPOLINE BOUNCES**

## THE BASIC BOUNCE

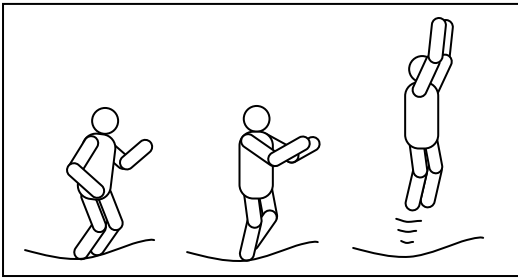

1. Start from standing position, feet shoulder width apart and head up and eyes on mat
2. Swing arms forward, up and around in a circular motion.
3. Bring feet together while in mid-air and point toes downward
4. Keep feet shoulder width apart when landing on mat.

## KNEE BOUNCE

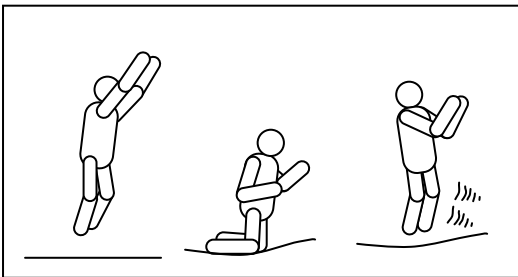

1. Start with basic bounce and keep it low
2. Land on knees keeping back straight, body erect. Use arms to maintain balance.
3. Bounce back to basic bounce position by swinging arms up

## SEAT BOUNCE

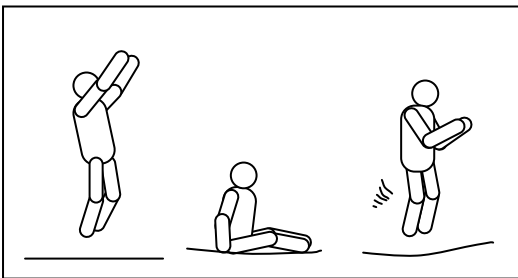

1. Land in a flat sitting position.
2. Place hands on mat besides hips
3. Return to erect position by pushing with hands.

## FRONT BOUNCE

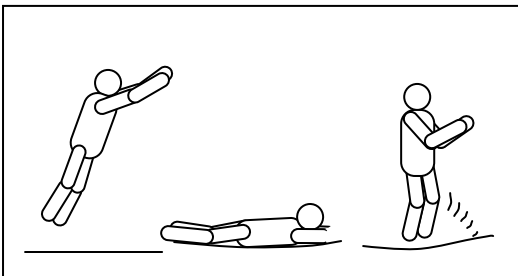

1. Start with a low bounce
2. Land in prone (face down) position and keep hand and arms extended forward on mat
3. Push off the mat with arms to return to standing position

## 180-DEGREE BOUNCE

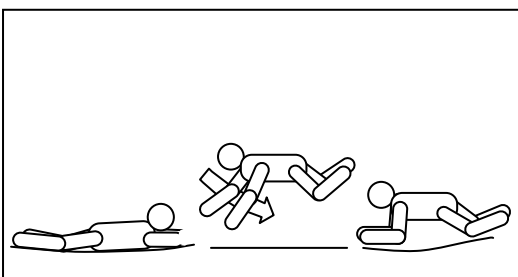

1. Start with front bounce position
2. Push off with left or right hands and arms (depending on which way you wish to turn)
3. Maintain head and shoulders in the same direction and keep back parallel to mat and head up
4. Land in prone position and return to standing position by pushing up with hands and arms

## FREQUENTLY ASKED QUESTIONS

**Question:** “One or more of my enclosure poles are bending, what should I do?”

**Answer:** Most likely you have too much tension on the enclosure Safety Net due to the Enclosure Pole Top straps being too tight, or the enclosure elastic bands on the bottom are routed incorrectly. See pages 18-19 for instructions on how to properly install your Safety Net. In some cases, the poles will bend after being inappropriately used as handholds, grips, or after someone has hung or swung from them. The poles are not designed to support prolonged or repeated tension from being pulled on, and any damage resulting from these actions is not covered under our limited warranty. Pictures are required for warranty replacement of this particular part.

**Question:** “My frame pad keeps shifting after just a few minutes of use. What can I do?”

**Answer:** You probably have your frame pad too tight. Reseat the pad by taking it completely off and following the directions in the “Frame Pad Assembly” section. Remember; do not try to stretch the elastic bands to their tightest point. The bands need some give as the jump mat they are attached to will move significantly when someone is jumping on the trampoline.

**Question:** “I need to order springs” or “I need to order a new frame pad, who do I contact?”

**Answer:** You can purchase springs, frame pads, safety nets, jump mats, and frame steel pieces directly from Pure Fun. Please submit your request via e-mail at: [customerservice@jamzproducts.net](mailto:customerservice@jamzproducts.net), or you can call **888-498-5269** to speak with a representative. If you still have your proof of purchase, you may be eligible for a discounted rate even if you are out of warranty.

**Question:** “Something was missing from the packaging,” or “I discovered a damaged piece during assembly” or “I’m within my warranty period (specific information found on page 2), and I need a part that broke due to a manufacturer’s defect, what can I do?”

**Answer:** Contact Jamz customer service at: [customerservice@jamzproducts.net](mailto:customerservice@jamzproducts.net) or by calling **888-498-5269**. You must have your proof of purchase and/or order confirmation available to be considered for warranty replacement. You must report missing pieces within 30 days from date of purchase. Please be aware that under our limited warranty, for some parts we require a picture of the damaged item and/or return of the item to our quality control office for review.

For more information on this product please visit [www.JamzProducts.net](http://www.JamzProducts.net)

Thank you for purchasing a Pure Fun Trampoline, and I hope you and yours enjoy it for many years to come!